

ROUGH SERVICE LED LUMINAIRE

Model 100-LED-4K4

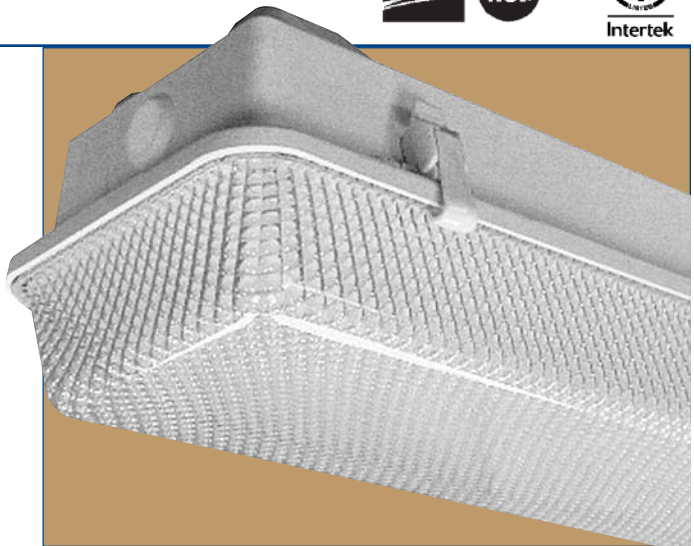

Energy saving LED linear luminaire combines efficiency and style with reduced operating costs. Operates efficiently at temperatures down to -40°C (-40°F) and up to 50°C (122°F). **Quality engineered to resist rust, corrosion, moisture, dust and impact.** Non-conductive housing assures more safety to the end user. The impact-resistant **polycarbonate** lens is less prone to damage. The smooth lens exterior allows ease of cleaning while the prism interior provides uniform light diffusion. LEDs selected with a **high R9 Value** would make this luminaire ideally suited for food processing areas such as meat cutting rooms and meat display counters, as well as being suitable for hospital operating rooms and similar applications. Other applications for this luminaire with white LEDs are general display counters in grocery stores and markets, classrooms and administrative areas in schools and universities, parking garages, government and civic facilities, car washes, commercial and industrial facilities, marine and public access areas, and freezer and cold storage areas. High quality LEDs and Driver ensure high reliability and durability while delivering low power consumption.



LEDs contain no mercury and emit no ultraviolet light.

LEDs will not break, unlike conventional lamps, if fixture is dropped.

Specifications

Lens:	Vacuum-formed impact resistant polycarbonate lens facilitates maximum light control and emission. Smooth exterior allows ease of cleaning. Edge is flanged to fit snugly into the gasketed retention channel for a continuous seal against moisture and dust.
Housing:	Compression-molded fiberglass reinforced polyester (self-extinguishing ASTM D635-74). One-piece construction designed to facilitate portability.
Gasket:	Continuous poured-in-place gasket fills the perimeter channel of the housing and snugly accepts lens flange for maximum seal integrity against moisture and dust. Gasket cannot separate, shift or fall out.
LEDs:	High Quality White Lighting Grade LEDs LEDs mounted on .125" thick aluminum plate. 5,000K-7,000K Color temperature. Lumens: 4,400 Watts: 42 L70 lifetime up to 50,000 hours. High R9 Value LEDs — Ideal for meat cutting rooms and meat counters, or in hospital operating rooms Warranted for five (5) years.

Driver: **High Quality Driver**
Class 2 Power Supply.
120-277 VAC, 60Hz.



Complies with FCC rules and regulations, as per Title 47 CFR Part 15 Non-Consumer (Class A) for EMI/RFI (conducted and radiated) at full load.

Warranted for five (5) years by Driver manufacturer.

Hardware: Two (2) corrosion resistant brass 1/4-28x3/8 fixture mounting studs, molded into the housing and integral to the unit.

Mounting (Optional): Mounting Strap for flush mount, Eyebolt Bracket for chain mount (Chain not included).

Latches: Standard are two pairs of white injection molded high impact Celcon suitcase style latches that secure a positive seal between housing, gasket and lens. Special tamperproof latches of stainless steel (for marine applications) or polycarbonate are available as a custom component. W. F. Harris Lighting recommends using the optional stainless steel latches for any luminaire being used outside.

ETL-US and ETL-C Listed (UL1598)
LM-79 and LM-80 Test Data Available
USDA Certified for Food Area Applications.
NSF Certified for Non-Food Zone Applications.

The polycarbonate lens carries a flammability rating of 94HB or better.
The self-extinguishing fiberglass housing has the superior rating of SE-O.

Luminaire Type _____
Catalog Number _____
Product Code _____
Job Name _____
Approval _____



**SBA QUALIFIED
SMALL BUSINESS MANUFACTURER**

TAA COMPLIANT
TRADE AGREEMENT ACT COMPLIANT

W.F. Harris Lighting, Inc.

Innovative Lighting Designs Since 1970

P.O. Box 5023, Monroe, NC 28111-5023, USA
704.283.7477 (HEADQUARTERS) • 800.842.9345 (TOLL FREE)
e-mail: customerservice@wfarris.com
www.wfharrislighting.com

Form 2573

2/17

"A Live Operator Company Standing Ready to Serve Your Lighting Needs."

ROUGH SERVICE LED LUMINAIRE

Ordering Information

Fill In Blocks For Complete Catalog Number

	-	
--	---	--

Model

100-LED-4K4

Options

MS-Mounting Strap Installation Kit (Contains 2)
BRKTS2-Chain Mounting Installation Kit (Contains 2) (Chain not included.)

LSS-3-Stainless Steel Latches*
LSS-3TP-Stainless Steel Tamperproof Latches*
LCWTP3-Tamperproof Celçon Latches*
LPC-Polycarbonate Latches*
LPCTP3-Tamperproof Polycarbonate Latches*

*Special Latches Available as Custom Components.
Consult Factory for Availability.

Dimensions

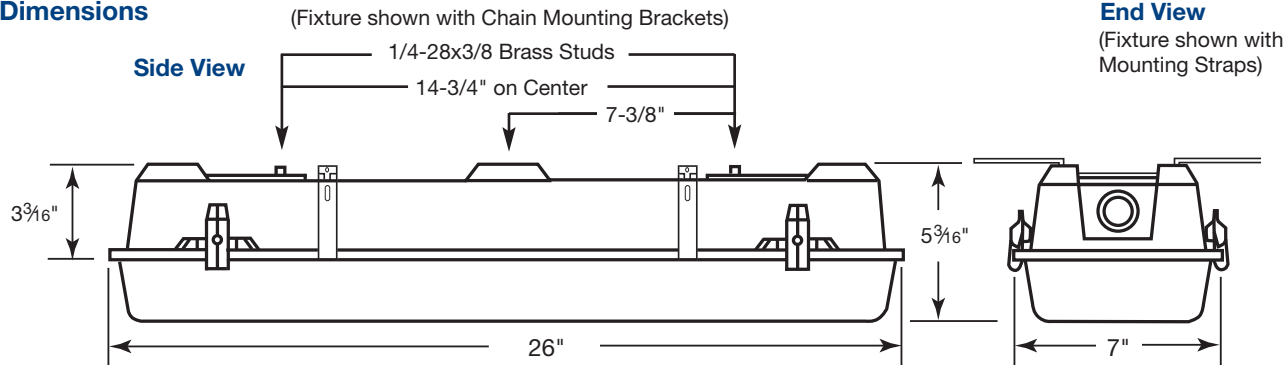

LEDs and the W. F. Harris Lighting Advantage

The lighting grade LEDs used by W. F. Harris Lighting provide the long sought-after stability demanded for commercial illumination in brightness, efficacy, life time, and color temperatures. Can be used in commercial/industrial illumination applications, hospitals, schools, universities, government buildings, military installations and freezer applications.

W. F. Harris Lighting LED-based luminaires reduce ownership costs through four factors —

- (1) Maintenance avoidance – LEDs last much longer than traditional lamps plus the fixture is non-rusting and vandal resistant.
- (2) Reduced energy cost of the LEDs.
- (3) Reduced cost in operation of freezer compressors due to lower wattage and less heat.
- (4) LEDs do not break if dropped, unlike conventional lamps.

These lighting grade LEDs offer efficient illumination that - depending on the application - can last up to 100,000 hours before their light output falls below 70% of original illumination and even longer in refrigerated environments.

Application-specific units available to meet a customer's unique lighting requirements.

After the customer provides W. F. Harris Lighting with specific requirements for a lighting application, our in-house LED Application Engineering Department will adjust the fixture to satisfy those requirements. Once completed, a Product Code will be assigned and used to order application-specific units.



**SBA QUALIFIED
SMALL BUSINESS MANUFACTURER**

TAA COMPLIANT
TRADE AGREEMENT ACT COMPLIANT

W.F. Harris Lighting, Inc.

Innovative Lighting Designs Since 1970

P.O. Box 5023, Monroe, NC 28111-5023, USA

704.283.7477 (HEADQUARTERS) • 800.842.9345 (TOLL FREE)

e-mail: customerservice@wfharris.com

www.wfharrislighting.com

**POLYCARBONATE LENS CARRIES A
LIFETIME WARRANTY AGAINST BREAKAGE.**

Printed in USA

Form 2573

2/17

Specifications Subject to Change Without Notice.

"W. F. Harris Lighting Will Not Sacrifice Quality for the Sake of Price."